

TS2001

Smart
Pressure Switch

User Guide

Contents

Basic Information.....	1
Brief technical description.....	1
Installation and electrical connection.....	1
Installation of USB drivers for Windows OS.....	1
TS2001 User Software.....	5
Output function diagram depending on the set configuration:.....	5
TS2001 Configuration.....	6
Recommended connection.....	6
Dimensional sketch.....	7
Ordering specifications:.....	7
Technical parameters.....	8

Basic Information

- piezoresistive or ceramic pressure sensor
- digital data processing with compensation of temperature dependencies and non-linearity of measurements
- outputs programmable in pressure or level units with hysteresis option at each output
- contactless galvanically isolated outputs with the possibility of switching DC / AC voltage
- configuration SW for Windows

Brief technical description

The TS2001 smart pressure switch is designed for discontinuous control and indication of pressure using two-state outputs. The switch includes a piezoresistive or on request a ceramic pressure sensor depending on compatibility with the medium to be measured. Measured data are digitally processed with digital compensation of temperature dependencies and measurement non-linearity. At the output, the contactless switches are galvanically isolated from the supply voltage and from each other. Outputs are bidirectional, that means, they can switch DC and AC voltages in any polarity.

The entire device is configurable from a PC, it is possible to choose the function of each switch, the level and hysteresis of the pressure for switching. The advantage of the switch is full digital setting from a PC without the need for manual tuning according to the manometer, high accuracy of pressure measurement and correction of the temperature dependence of the sensor. The pressure switch is particularly suitable, for example, for measuring the level using hydrostatic pressure, where the resolution is 1 mm at a water level of 10 m.

Installation and electrical connection

The switch has an optional pressure connection with a G1/4 or G1/4 DIN 3852 female thread. The electrical connections of the converter should be carried out using shielded wires to ensure the resistance of the converter against electromagnetic influences of the environment. The supply voltage of the switch is 12 to 30 V DC, the outputs are solid state, contactless. An informative picture of the output connection can be found in the paragraph **Recommended connection**.

Installation of USB drivers for Windows OS

Open the cover of the pressure switch, connect the pressure switch to the power supply and to the PC via USB cable AB. Press Win + X or right click on the Windows icon to open the Quick Access menu. Select Device Manager from the menu.

You will see the following image on the monitor:

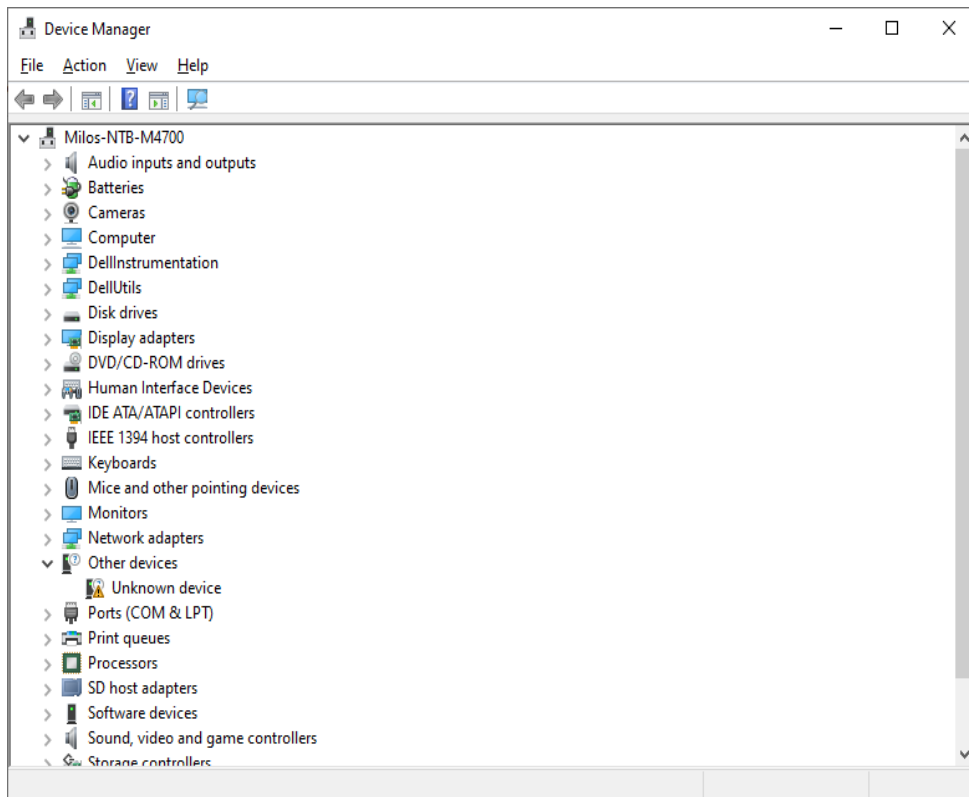

The pressure switch is shown as **Other Device/Unknown Device**. From the context menu on the right mouse button, select **Update driver**.

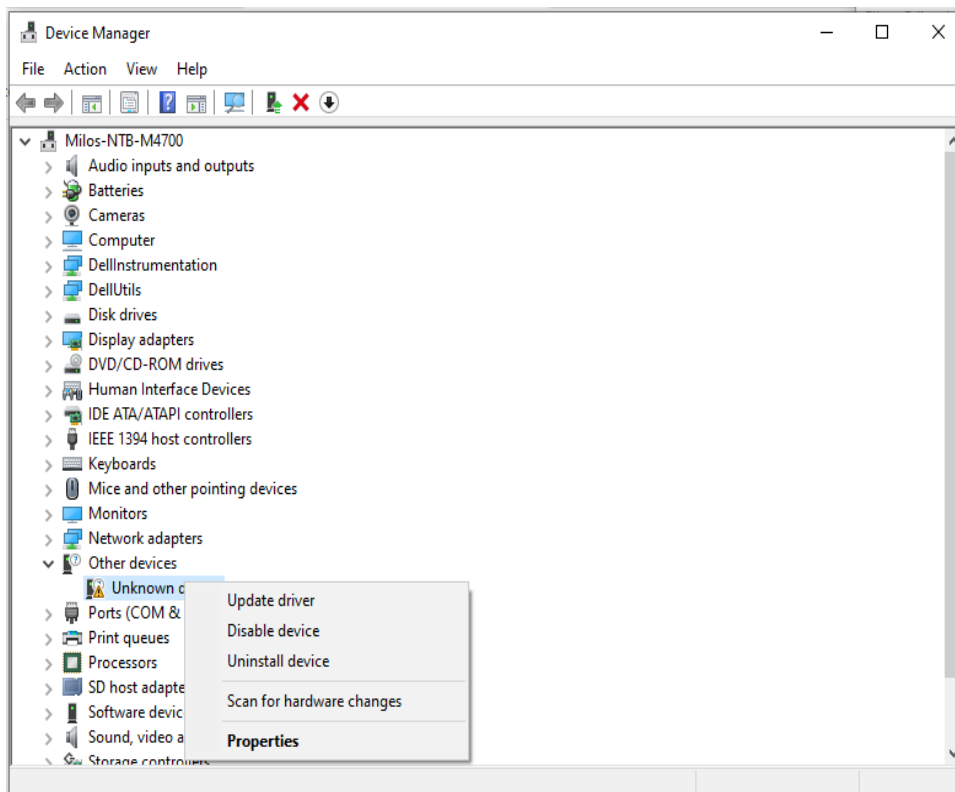

In the following window, select **Search for drivers on my computer**.

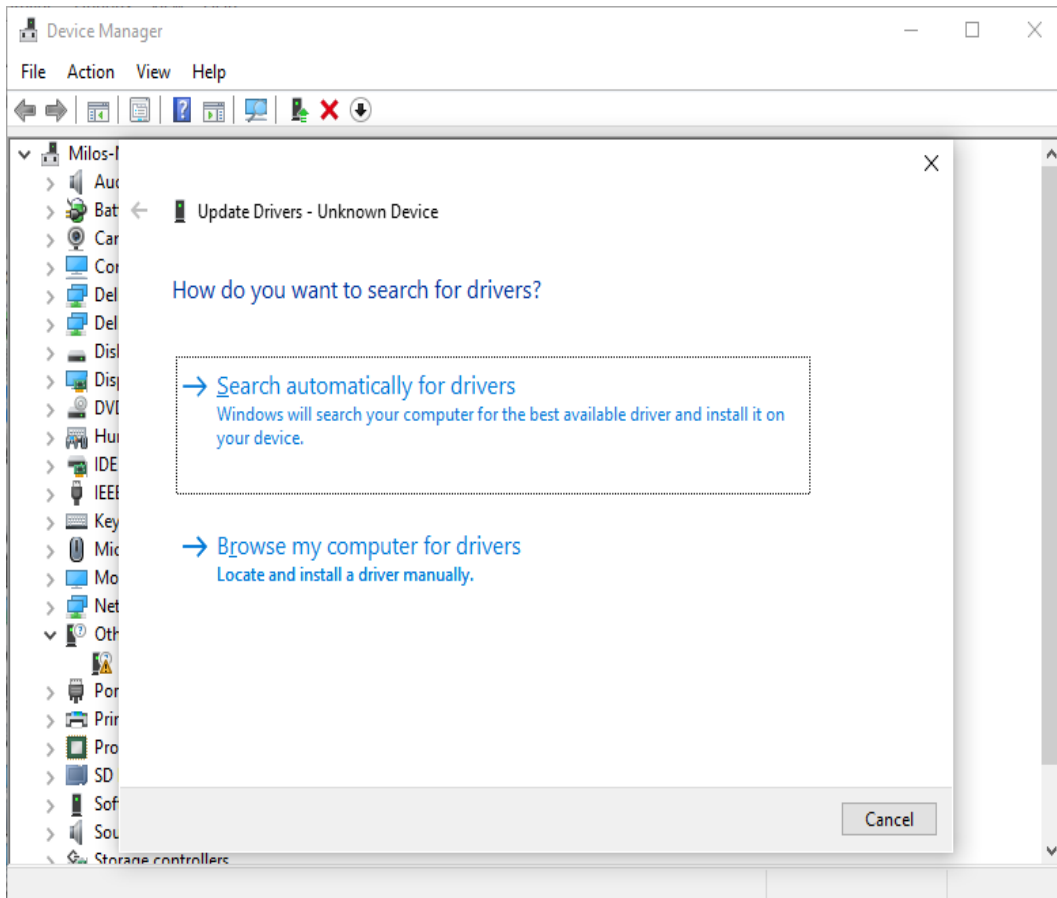

Proceed with **Browse**:

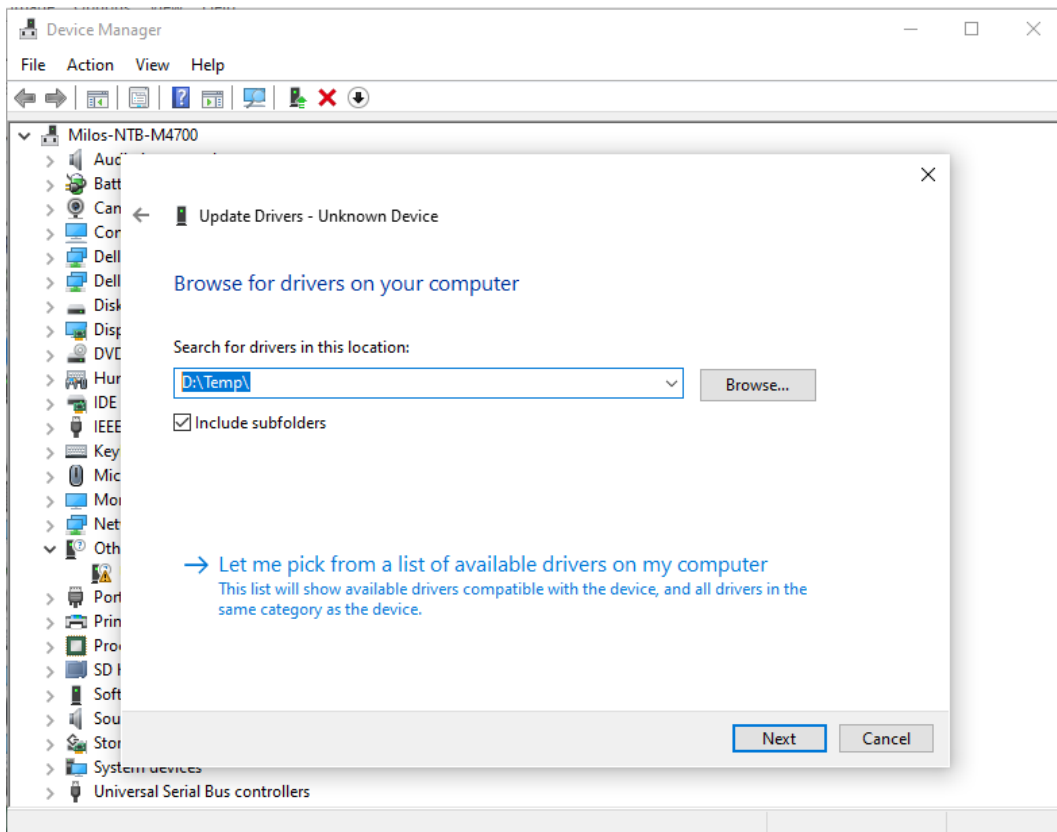

Select the folder where the drivers are located

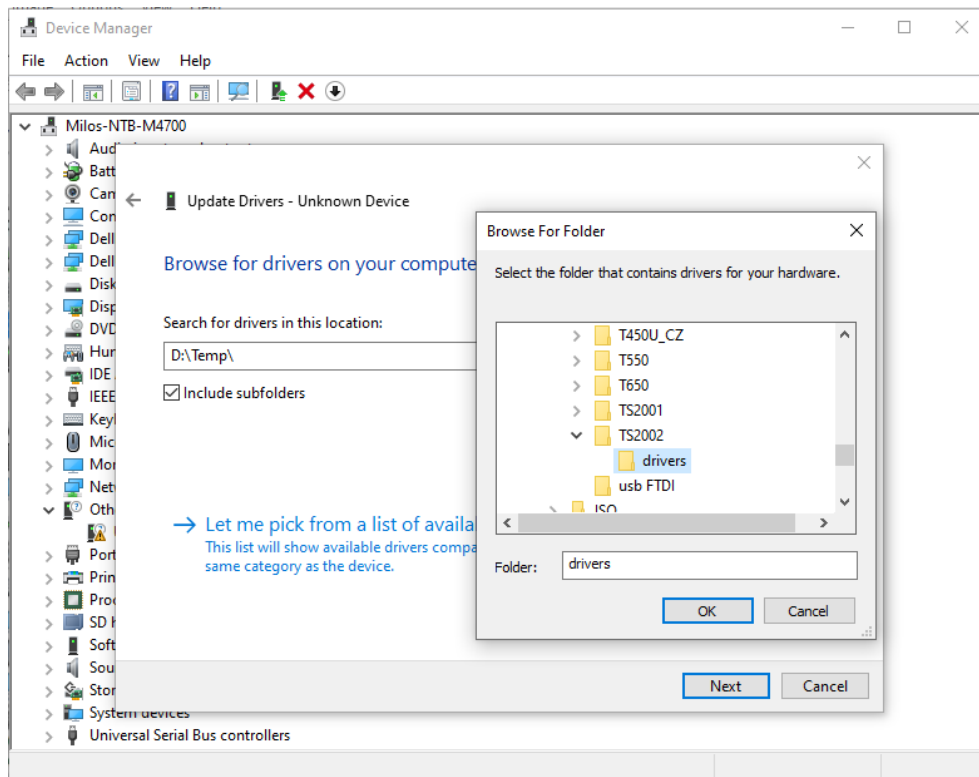

After selecting the correct folder and installing the drivers, you will see the pressure switch logged as a Microchip Custom USB Device. TS2001 User software

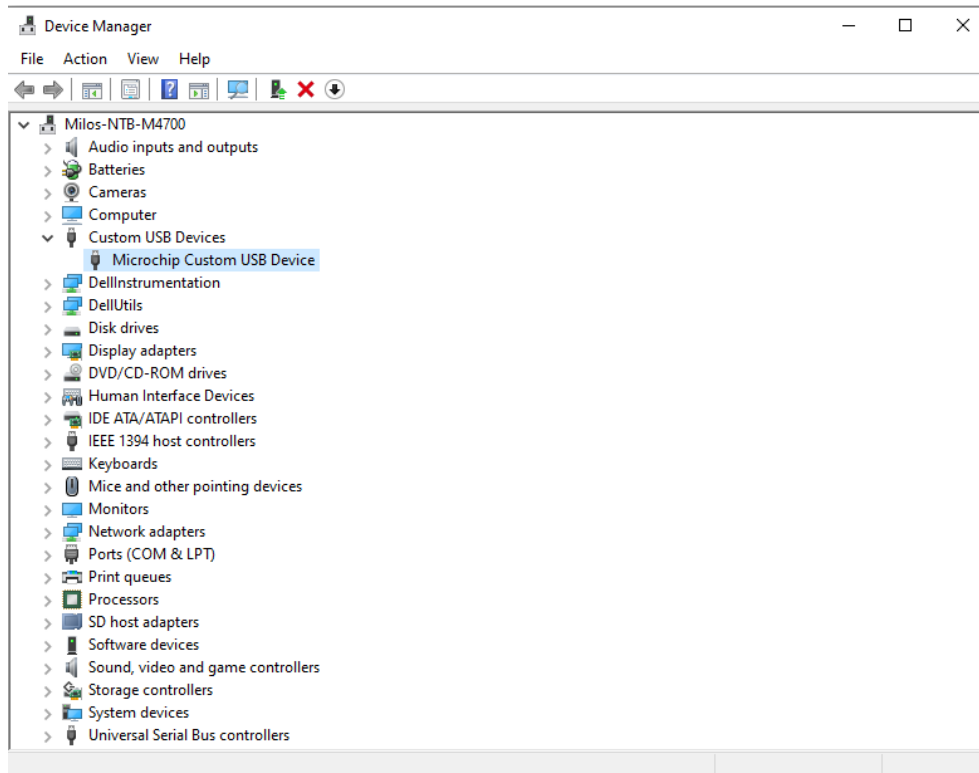

TS2001 User Software

Configure the pressure switch using the TS2001 User Software application, the installation package of which can be downloaded from the SV Technics s.r.o. website.

<https://www.svtechnics.cz/en/download/>

Configuration from the application graphical interface is very simple and intuitive. You can choose to configure in units of pressure or, for working with hydrostatic pressure, to configure in units of length. In this case, you should also enter the specific density of the liquid. The application converts the set liquid column height to pressure and the pressure units are again entered into the instrument.

In the Configuration window there are output function options

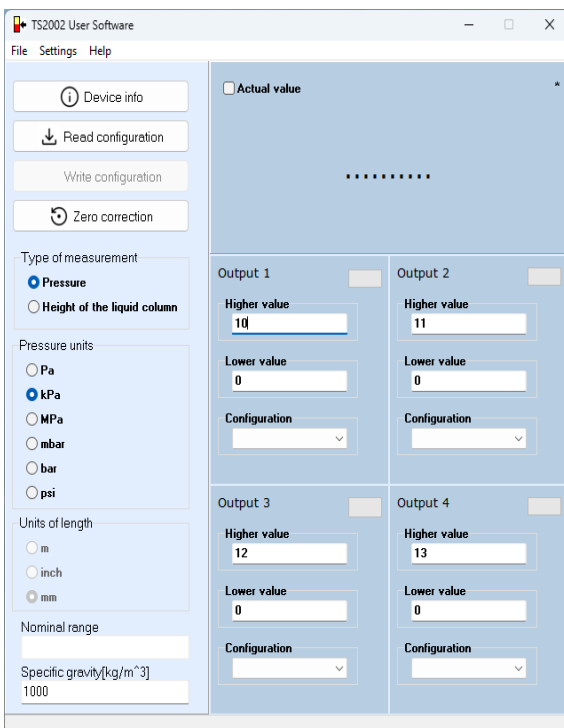

- Off - output with no function
- Compression – the switch opens when a higher pressure is reached and closes when the pressure drops below the lower limit
- Suction – the switch opens when a lower pressure is reached and closes when it rises above the higher limit
- Correct pressure - the switch is closed between the higher and lower pressure limits
- Error pressure - the switch is closed outside the higher and lower pressure limits

Output function diagram depending on the set configuration:

Compression

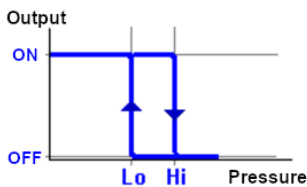

Suction

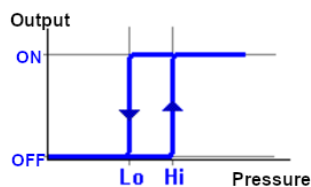

Correct pressure

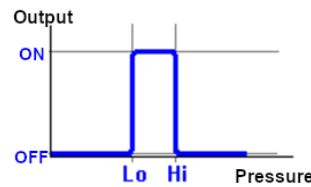

Error pressure

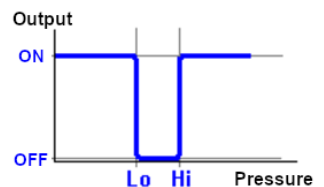

Lo - lower decisive limit (level)

Hi - higher decisive limit (level)

TS2001 Configuration

Open the pressure switch box and connect the USB cable A/B to the pressure switch board connector. When the TS2001 User Software application is started, the current pressure switch setting is read. If you need to change the settings, follow the steps in the **TS2001 User software**. After setting up your own configuration, upload it to the instrument. If you often work with the same configuration, you can save it to or load from your computer hard drive or external disk.

The application also displays current pressure values and output states. The last function of the application is Zero correction, which is used to correct the long-term instability of the zero value of the pressure sensor (see the switch technical parameters). To correct the zero value, it is necessary to ensure zero pressure at the input of the switch, preferably by disconnecting the switch from the pressure circuit.

Detailed operating instructions and a description of all functions can be found in the application help section.

Recommended connection

Use shielded wires connected to the PE terminal separated

Outputs are bidirectional and completely

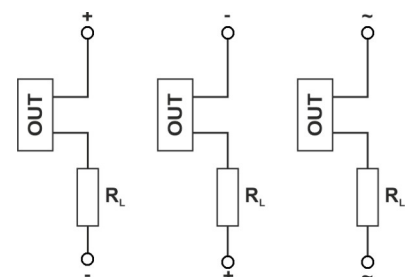
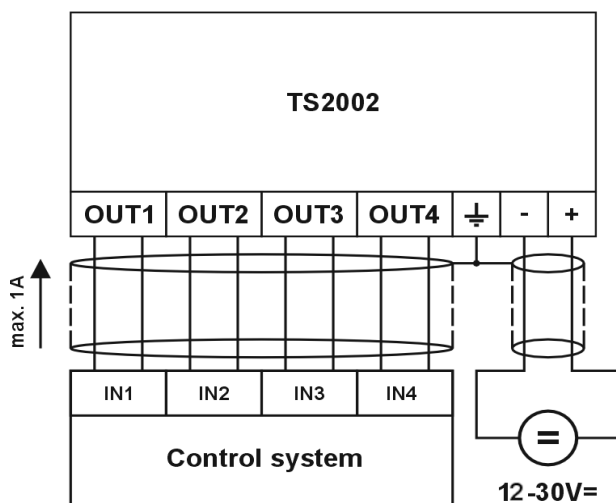

Dimensional sketch

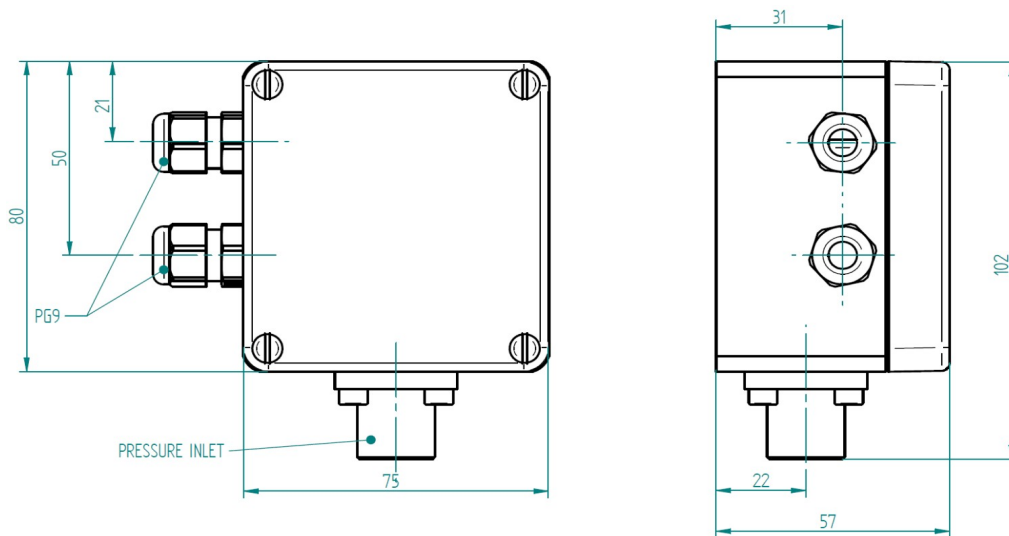

Ordering specifications:

TS2001 - XXY - Z - W

where **XX** pressure range in kPa, standard manufactured ranges in series 1, 2, 5

Y pressure exponent, e.g. **500** = 50 kPa, **101** = 100 kPa, **202** = 2 MPa

Z type of pressure sensor: **P** piezoresistive, **K** ceramic

W pressure connection: **A** inner thread G1/4 x 10, **B** G1/4 DIN 3852

Technical parameters

Power supply		Switched voltage	max 30 V DC, 24 V eff. AC
Power supply voltage	12 to 30 V DC	Switched current	max 1 A AC/DC
Consumption	30 mA max.	Isolation voltage	500 V DC max against all other terminals
Electrical connections		Environmental specifications	
Terminal blocks for power supply and contactless outputs	Cross section 0 - 1.5 mm ²	Ambient temperature	-5 to +60°C
USB port	type B - inside the box	Ambient humidity	5 to 90% without condensation
Pressure measurement		Storage temperature	-40 °C to +80°C **
Pressure sensor	piezoresistive or ceramic *	Designed for	indoor and outdoor use
Nominal range	10 kPa to 40 MPa in series 1,2,5	Mechanical properties	
Allowed overpressure	+ 100% of the nominal range	Box material	aluminium
Measured media	non-corrosive media, corrosive media compatible with 316 stainless steel and FKM materials	Ingression protection	IP65, connection with round cables
Pressure connection	inner thread G1/4 x 10, G1/4 DIN 3852 *	Dimensions (W x H x L)	100 x 100 x 58 mm
Pressure error (linearity, hysteresis error, repeatability)	< ± 0.25% of nominal range	Weight	415 g
Temperature error within the temp. range	max. ± 0.5% of the nominal range		
Medium temperature	-20 to +100°C **	Approval according to directives and standards	
Features of contactless outputs		EMC	EN IEC 61326-1 :2020
			EN 50121-3-2 ed. 4:2016 + Amendment A1:2019
Number of outputs	3	ROHS	EN IEC 63000

Note:

* to order

** the pressure space of the instrument must not be filled with liquid medium with a freezing point above the temperatures of use or storage.